



**LITTLE ROCK WASTEWATER  
BID SPECIFICATIONS FOR  
MANHOLE RINGS AND LIDS AND 2" EXTENSION RING**

**Bid Number:** 010-2011

**Open Date:** December 8, 2011

**Time:** 2:30 P.M., C.S.T.

**To:** Manufacturers/Distributors of Manhole Rings and Lids

**Bid Shall Meet or Exceed the Following Minimum Specifications:**

The Purchasing Office of Little Rock Wastewater, 11 Clearwater Drive, Room 129, Little Rock, AR 72204, will accept sealed bids until 2:30 P.M., C.S.T., Thursday, December 8, 2011 for the purchase of 200-each Manhole Rings and Lids, and 150-each 2-inch Manhole Extension Rings.

Bidders are requested to quote price F.O.B. destination delivered, **by means of an open flat bed trailer**. Delivery shall be made by the hours of 9:00 A.M., C.S.T. to 3:00 P.M., C.S.T. between Tuesday and Thursday to the following location:

**Clearwater Maintenance Complex  
5300 South Shackleford Road  
Little Rock, AR 72204**

**Note: See Attached Drawings and Minimum Weights.**

- A. Covers must have the words LITTLE ROCK SANITARY SEWER, and PERMIT REQUIRED CONFINED SPACE cast in top of Manhole Lid.
- B. Manhole Lids shall have two (2) closed pick holes in top of lid.
- C. Minimum combined weights of the Manhole Ring and Lid shall be 240-pounds. Minimum Lid Weight shall be 115-Pounds; Minimum Ring Weight shall be 125-Pounds.
- D. All castings shall be cast with the approved foundry's name, manufacturing factory mark, part number, and production date in month

day, and year, on the inside of the lid. All castings shall be manufactured in the USA and shall be clearly marked "Made in the USA".

- E. All Castings: Free from porosity, blowholes, hard spots, shrinkage, distortion and other defects; smooth and well cleaned by sandblasting and, manufactured true to pattern.
- F. Ring and Lid Dimensions: Refer to Standard Detailed Drawings. Final casting dimensions may vary + or - 1/16 inch per foot.
- G. Rings and Lids bearing surfaces; smooth finish, non-rocking design or machined bearing surfaces to prevent rocking and rattling under traffic.
- H. Cast Iron: ASTM A 48, Class 35B.
- I. Ductile Iron: ASTM A 536, Grade 80-55-06.
- J. Approved Standard Manhole Ring and Lid Manufacturers:
  - a. East Jordan Iron Works
  - b. Bass & Hays Foundry
  - c. Deeter Foundry
  - d. Or approved equal

Bidder is requested to contact Little Rock Wastewater, Clearwater Storeroom, with a 24-hour advance notice to deliver. Bidder shall contact any of the following individuals: Edward Sheppard, at (501) 223-1511, or James Adams, at (501) 223-1519 between the hours of 8:00 A.M. and 4:30 P.M., Monday through Friday, C.S.T.

Should any additional information be required regarding this bid, contact Trudy Noble; CPPB, Purchasing Supervisor, (501) 688-1442 between the hours of 8:00 A.M. and 4:30 P.M., Monday through Friday.

Little Rock Wastewater encourages all minority and women's business enterprises to inquire and submit a bid if you are a provider of this type of material.

Little Rock Wastewater Reserves the right to reject any and all bids and to waive any and all informalities.

Little Rock Wastewater

Trudy Noble, CPPB  
Purchasing Supervisor

**Bid Number: 010-2011**

**Manhole Rings and Lids and 2" Extension Ring**

<b><u>Item Number</u></b>	<b><u>Description</u></b>	<b><u>Unit Cost</u></b>	<b><u>Total Cost</u></b>
1.	200-Ea. Manhole Rings & Lids	\$ _____	\$ _____
2.	150-Ea. 2-Inch Manhole Extension Rings	\$ _____	\$ _____

**Total Bid Amount: \$ \_\_\_\_\_**

**Cash Discount: \_\_\_\_\_ % \_\_\_\_\_ Days**

**Manufacturer: \_\_\_\_\_**

**Model Number: \_\_\_\_\_**

**Delivery Date: \_\_\_\_\_**  
(Delivery shall be made on or after January 2010)

**Price shall stay firm for 60 calendar days.**

**REQUIREMENTS FOR BID**

We, the undersigned, have read all the requirements set forth in this bid proposal including the specifications, instructions, conditions, and pertinent information regarding the articles being bid on, and we agree to furnish these items at the prices stated.

**BIDDER: \_\_\_\_\_**

**ADDRESS: \_\_\_\_\_**

**CITY, STATE, AND ZIP CODE: \_\_\_\_\_**

**BY: \_\_\_\_\_ PRINT NAME: \_\_\_\_\_**  
(Person Authorized to Sign Bid)

**PHONE NUMBER: \_\_\_\_\_ DATE: \_\_\_\_\_**

**UNSIGNED BIDS WILL BE REJECTED  
BIDS ARE SUBJECT TO REJECTION UNLESS SUBMITTED ON THIS FORM  
SEE ATTACHED SHEET FOR CONDITIONS OF BID**

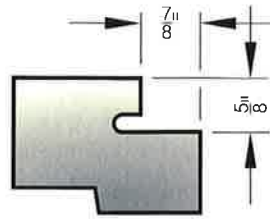

**CLOSED PICK SLOT DETAIL**

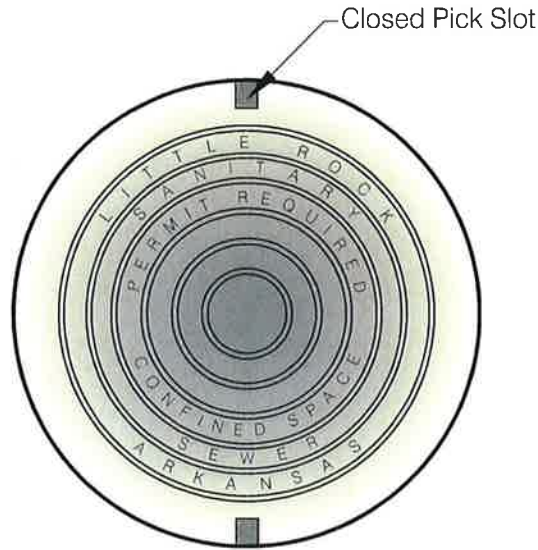

**LID DETAIL**

1. Minimum weight of ring: 125 pounds
2. Minimum weight of lid: 115 pounds
3. Lids are furnished with two closed pick slots.
4. Castings shall be "Made In USA"

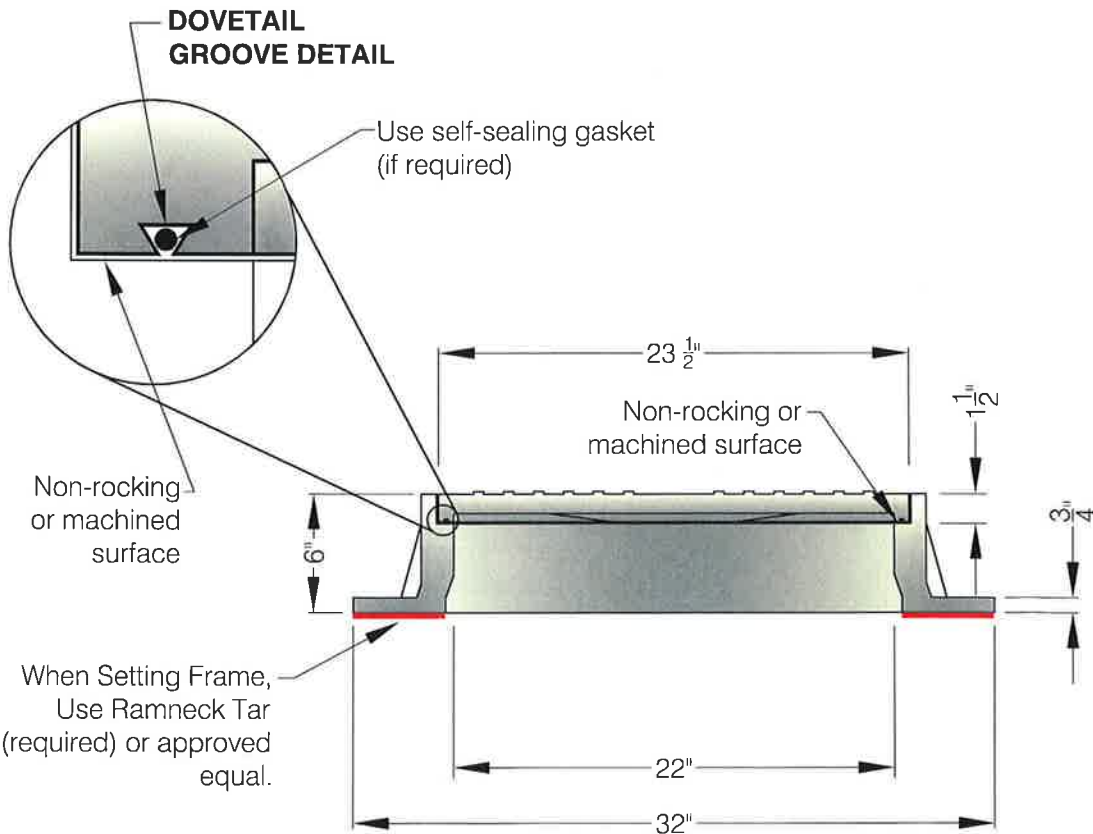

**RING DETAIL**

Note:  
Dimensions shown may vary by  $\pm \frac{1}{2}$ " with the exception of the Lid dimension.

LRW

1.12

**STANDARD RING & LID DETAILS**  
TO BE USED WITH  
**4' DIAMETER MANHOLES**



Prepared By: Evangeline O'Neal  
12/15/2008 1:51:13 PM  
Drawing Status: **APPROVED**  
Filename: LRW 1.12.dwg

1. ALL CHANGES/REVISIONS/ETC. MUST BE APPROVED BY THE LRW DIRECTOR OF ENGINEERING.

**Notes**

# 2" RING EXTENSION DETAILS



Prepared By: Evangeline O'Neal  
Updated: 12/15/2008 12:34:46 PM  
Drawing Status: **APPROVED**  
Filename: LRW 1.13.dwg

1. ALL CHANGES/REVISIONS/ETC. MUST BE APPROVED BY THE LRW DIRECTOR OF ENGINEERING.

## Notes

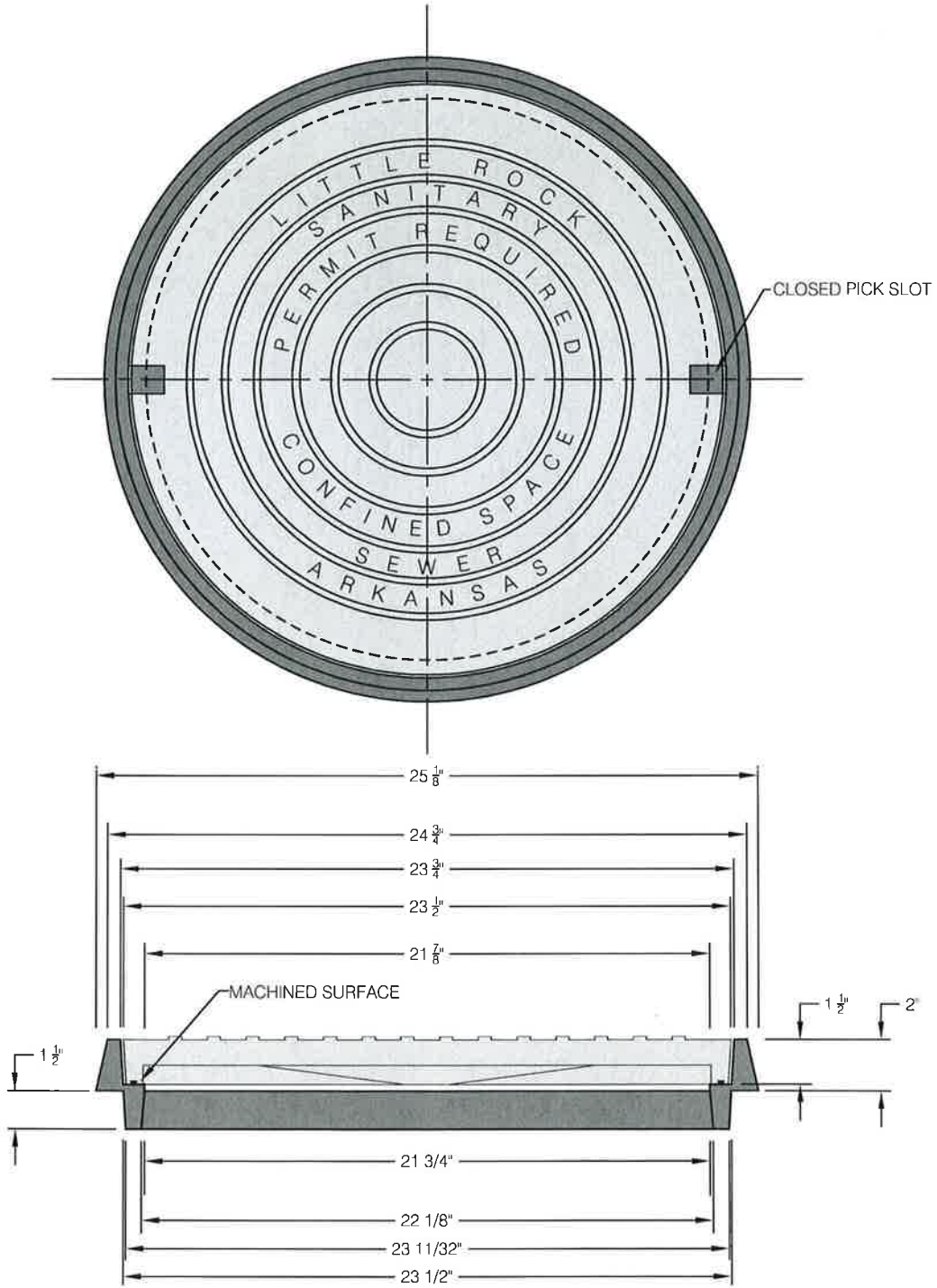

**CALCULATED WEIGHT OF 2" EXTENSION: 53 POUNDS  
CASTING SHALL BE "MADE IN USA"**